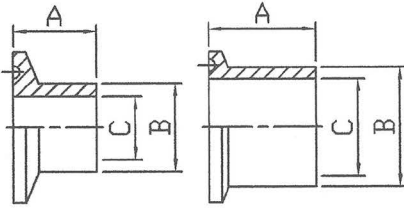
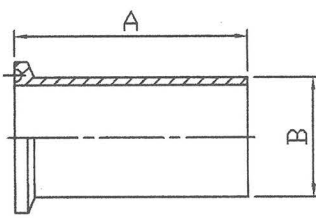
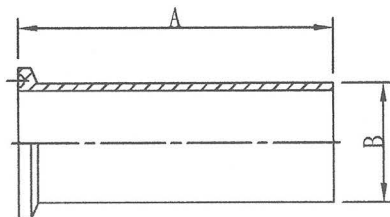
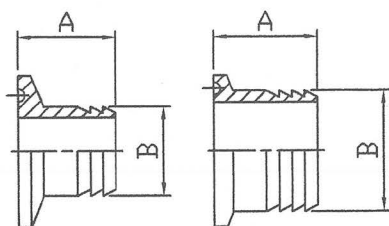

3A-14MPW 加厚接環		Welding Ferrule TANK Spud HEAVY WALL mm			t (thickness)	
		SIZE	A	B		C
		1"	41.3	29.5	22.1	3.7
		1 1/2"	41.3	42.6	34.8	3.9
		2"	44.5	55.7	47.5	4.1
		2 1/2"	44.5	68.8	60.2	4.3
		3"	46.0	81.9	72.9	4.5
		4"	54.0	108.1	97.4	5.35

3A-14WLMP 加長接環		Welding Ferrule TANK Spud LIGHT mm		t (thickness)	
		SIZE	A		B
		1"	76.2	25.4	1.65
		1 1/2"	76.2	38.1	1.65
		2"	76.2	50.8	1.65
		2 1/2"	76.2	63.5	1.65
		3"	101.6	76.2	1.65
		4"	101.6	101.6	2.1
		6"	152.4	152.4	2.8

3A-14MPHT 特長接環(Tygon管接頭)		TYGON HOSE ADAPTER mm		t (thickness)	
		SIZE	A		B
		1"	114.3	25.4	1.65
		1 1/2"	114.3	38.1	1.65
		2"	114.3	50.8	1.65
		2 1/2"	114.3	63.5	1.65
		3"	114.3	76.2	1.65
		4"	117.5	101.6	2.1

3A-14MPHR 軟管接頭		RUBBER HOSE ADAPTER mm		
		SIZE	A	B
		1"	42.8	25.4
		1 1/2"	42.8	38.1
		2"	58.7	50.8
		2 1/2"	59.5	63.5
		3"	78.6	76.2
		4"	86.5	101.6
		6"	101.6	152.4