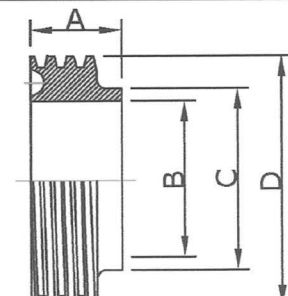
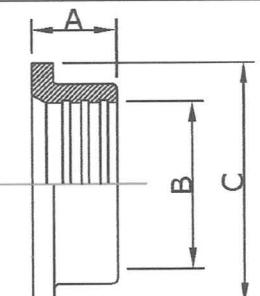
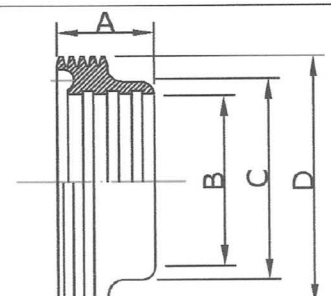
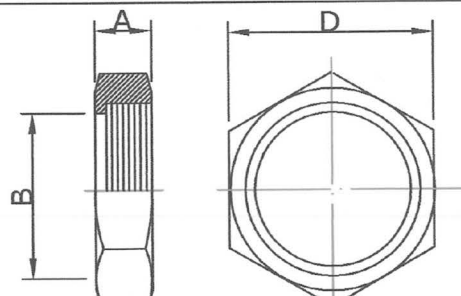

CIP15 CIP外牙接頭 (CIP FLAT FACE)	Weld MALE, CIP FLAT FACE					mm
	SIZE	A	B	C	D	Threads/Inch
	1"	22.2	22.2	25.8	45.7	8
	1 1/2"	22.2	34.9	38.5	58.6	8
	2"	22.2	47.6	51.2	72.5	6
	2 1/2"	22.2	60.3	63.9	85.3	6
	3"	22.2	73.0	76.6	97.9	6
	4"	22.2	97.6	102.0	123.2	6
	6"	19.0	148.5	152.8	174	6

RJT14R 擴管無牙接頭	LINER for EXPANDING			mm
	SIZE	A	B	C
	1"	20.0	25.5	41.3
	1 1/2"	24.0	38.2	54.0
	2"	28.0	50.9	66.7
	2 1/2"	32.8	63.6	79.4
	3"	32.8	76.3	92.1
	4"	38.0	101.7	117.5

RJT15R 擴管外牙接頭	Threaded MALE for EXPANDING				mm
	SIZE	A	B	C	D
	1"	20.0	25.5	32.5	45.7
	1 1/2"	24.0	38.2	45.2	58.6
	2"	28.0	50.9	57.9	72.5
	2 1/2"	32.8	63.6	70.6	85.3
	3"	32.8	76.3	83.3	97.9
	4"	38.0	108.7	108.7	123.2

BS13H BSM六角螺母(母牙/內牙)	BSM HEX NUT (for RJT/BSM/CIP Flat Face) mm				
	SIZE	A	B	D	Threads/Inch
	1"	22.0	33.3	50.8	8
	1 1/2"	22.0	46.0	65.0	8
	2"	22.0	58.7	79.3	6
	2 1/2"	22.0	71.4	92.0	6
	3"	22.0	84.1	104.7	6
	4"	22.0	110.0	130.0	6
	6"	24.3	162.5	185.0	6