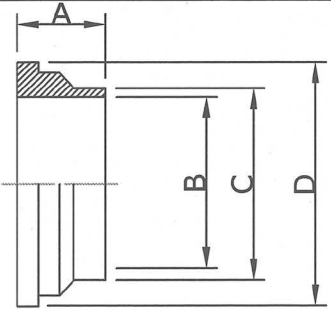
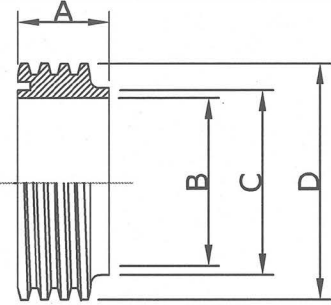
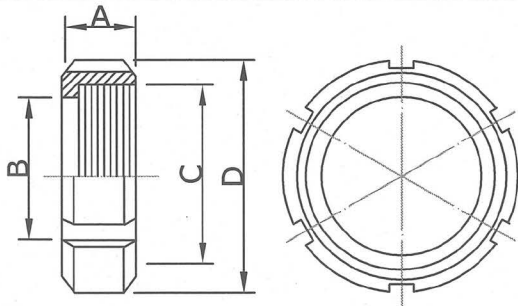
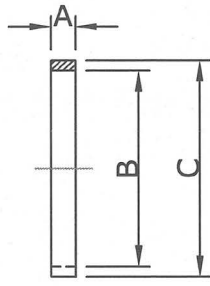

SMS14 焊無牙接頭 (長)	Weld LINER (SMS 1145)				mm
	SIZE	A	B	C	D
	1" (25)	15.5	22.5	25.0	35.5
	1 1/2" (38)	16.0	35.5	38.0	55.0
	2" (51)	17.0	48.5	51.0	65.0
	2 1/2" (63)	17.0	60.5	63.5	80.0
	3" (76)	19.0	72.9	76.1	93.0
	4" (104)	19.0	100.0	104.0	118.0
	4" EB(101.6)	19.0	97.6	101.6	118.0

SMS15 焊外牙接頭 (長)	Weld MALE (SMS 1145)				mm
	SIZE	A	B	C	D
	1" (25)	19.0	22.5	25.0	40 X 1/6
	1 1/2" (38)	23.0	35.5	38.0	60 X 1/6
	2" (51)	23.0	48.5	51.0	70 X 1/6
	2 1/2" (63)	27.0	60.5	63.5	85 X 1/6
	3" (76)	27.0	72.9	76.1	98 X 1/6
	4" (104)	30.0	100.0	104.0	125 X 1/4
	4" EB(101.6)	19.0	97.6	101.6	125 X 1/4

SMS13R 圓螺母(母牙/內牙)	ROUND SLOTTED NUT (SMS 1145)				mm
	SIZE	A	B	C	D
	1" (25)	19.0	32.2	40 X 1/6	51.0
	1 1/2" (38)	23.0	48.5	60 X 1/6	74.0
	2" (51)	24.0	61.0	70 X 1/6	84.0
	2 1/2" (63)	28.0	74.0	85 X 1/6	100.0
	3" (76)	30.0	87.0	98 X 1/6	114.0
	4" for 104 & 101.6	31.0	113.0	125 X 1/4	138.0

SMS40 SMS墊片	SMS GASKET (SMS 1145)			mm
	SIZE	A	B	C
	1" (25)	5.5	25.0	32.1
	1 1/2" (38)	5.5	38.0	48.1
	2" (51)	5.5	51.0	61.1
	2 1/2" (63)	5.5	63.5	73.6
	3" (76)	5.5	76.0	86.1
	4" for 104 & 101.6	5.5	104.0	116.2