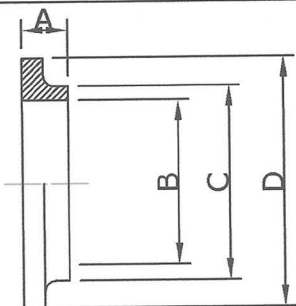
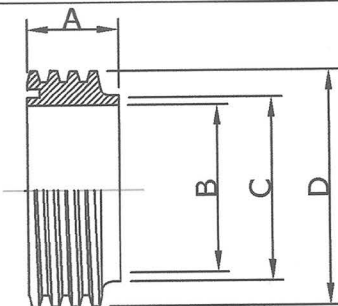
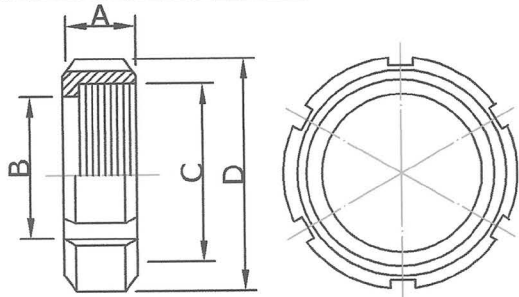

SMS14S 焊無牙接頭 (短)	Weld LINER SHORT (SMS 1145)				mm
	SIZE	A	B	C	D
	1" (25)	7.5	22.6	25.0	35.5
	1 1/2" (38)	9.0	35.6	38.0	55.0
	2" (51)	9.0	48.6	51.0	65.0
	2 1/2" (63)	9.0	60.3	63.5	80.0
	3" (76)	10.0	72.9	76.1	93.0
	4" (101.6)	12.0	97.6	101.6	127.0

SMS15S 焊外牙接頭 (短)	Weld MALE SHORT (SMS 1145)				mm
	SIZE	A	B	C	D
	1" (25)	15.0	22.6	25.0	40 X 1/6
	1 1/2" (38)	20.0	35.6	38.0	60 X 1/6
	2" (51)	20.0	48.6	51.0	70 X 1/6
	2 1/2" (63)	24.0	60.3	63.5	85 X 1/6
	3" (76)	24.0	72.9	76.1	98 X 1/6
	4" (101.6)	35.0	97.6	101.6	132 X 1/6

SMS13RS 圓螺母(母牙/內牙)	ROUND SLOTTED NUT (SMS 1145)				mm
	SIZE	A	B	C	D
	1" (25)	20.0	32.2	40 X 1/6	51.0
	1 1/2" (38)	25.0	48.5	60 X 1/6	74.0
	2" (51)	26.0	61.0	70 X 1/6	84.0
	2 1/2" (63)	30.0	74.0	85 X 1/6	100.0
	3" (76)	32.0	87.0	98 X 1/6	114.0
	4" (101.6)	45.0	117.0	132 X 1/6	154.0

*** SMS14S Weld Liner Short, SMS15S Weld Male Short and SMS13RS Round Slotted Nut are designed to used together with each other to form a complete set.