

## PARTS & MATERIAL LIST

No.	DESCRIPTION	SPECIFICATION
1.	BODY	ASTM A351 Gr.CF8M
2.	END CAP	ASTM A351 Gr.CF8M
3.	BALL	SS316
4.	BOLT WASHER	SS304
5.	BOLT NUT	SS304
6.	BOLT	SS304
7.	SEAT RING	PTFE
8.	BODY SEAL	PTFE
9.	THRUST WASHER	PTFE
10.	STEM	SS316
11.	O-RING	VITON
12.	STEM SEAL	PTFE
13.	GLAND RING	SS304
14.	BEVEL WASHER	SPRING STEEL
15.	GLAND NUT	SS304

## DIMENSIONS (mm)

SIZE	PORT	L	H	h	P	T	D	S	T1	T2	ISO 5211
1/2"	9.6	92.5	40	7	9	9	25.0	20.24	***	3.63	F03 PCD36 $\phi 6 \times 4$
											F04 PCD42 $\phi 6 \times 4$
3/4"	15.9	105	44	9	9	9	25.0	20.24	***	3.63	F03 PCD36 $\phi 6 \times 4$
											F04 PCD42 $\phi 6 \times 4$
1"	22.2	113	52	12	11	10	50.4	43.60	2.85	4.75	F04 PCD42 $\phi 6 \times 4$
											F05 PCD50 $\phi 7 \times 4$
1-1/4"	28.5	119.5	58	12	11	10	50.4	43.60	2.85	4.75	F04 PCD42 $\phi 6 \times 4$
											F05 PCD50 $\phi 7 \times 4$
1-1/2"	34.9	123.5	68	16	14	13	50.4	43.60	2.85	***	F05 PCD50 $\phi 7 \times 4$
											F07 PCD70 $\phi 9 \times 4$
2"	47.5	145	77	16	14	13	63.9	56.30	2.85	***	F05 PCD50 $\phi 7 \times 4$
											F07 PCD70 $\phi 9 \times 4$
2-1/2"	60.2	177	98	19	17	13	77.4	70.60	2.85	***	F07 PCD70 $\phi 9 \times 4$
											F10 PCD102 $\phi 11 \times 4$
3"	72.9	192	110	19	17	13	90.0	83.30	2.85	***	F07 PCD70 $\phi 9 \times 4$
											F10 PCD102 $\phi 11 \times 4$
4"	97.4	236	138	24	22	16	118.9	110.30	2.85	***	F10 PCD102 $\phi 11 \times 4$
											F10 PCD102 $\phi 11 \times 4$

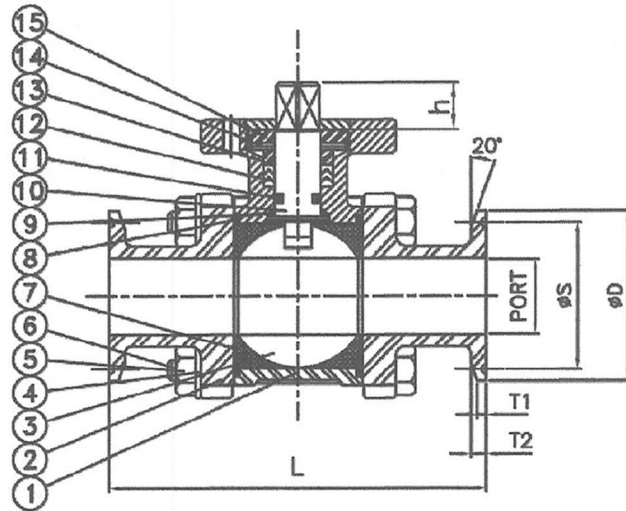
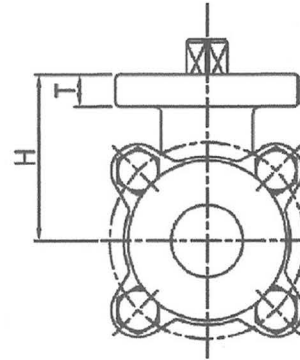
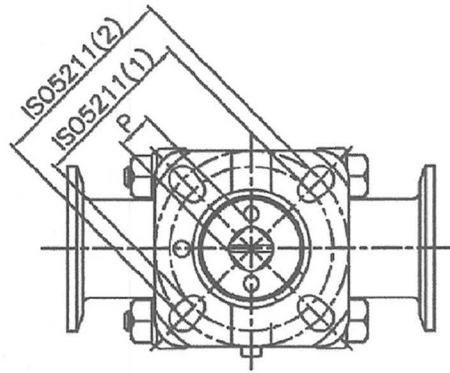

表面處理		表面粗度	
核准	核對	比例	----
程式	設計	單位	MM
日期	繪圖	材質	



**玄盛企業股份有限公司**  
 TECH CONTROL ENTERPRISE CO., LTD.

名稱

3片式手動球閥  
 3-PC Manual Ball Valve  
**5N1C BOV-C**

形式  
 圖號

無手把  
 without handle  
**5N1C**