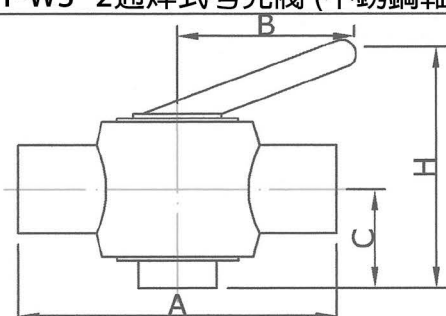
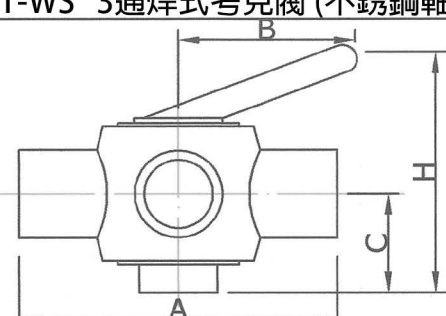
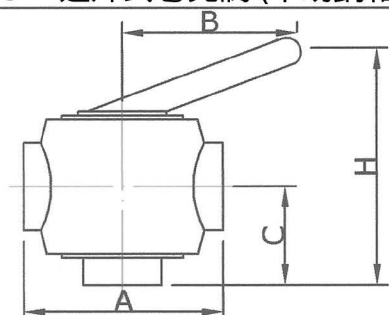
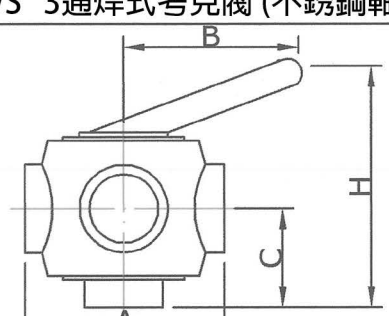

PLV-2T-WR 2通焊式考克閥 (橡膠軸) PLV-2T-WS 2通焊式考克閥 (不銹鋼軸)	2 Way Plug Valve Weld Ends				Rubber Plug SS Plug	mm
		SIZE	A	B	C	H
	1"	184.2	117.0	58.3	128.4	
	1 1/2"	198.4	142.7	61.0	164.4	
	2"	223.8	144.2	72.4	178.3	
	2 1/2"	260.4	150.6	86.2	223.4	
	3"	290.5	180.7	90.6	241.4	

PLV-3T-WR 3通焊式考克閥 (橡膠軸) PLV-3T-WS 3通焊式考克閥 (不銹鋼軸)	3 Way Plug Valve Weld Ends				Rubber Plug SS Plug	mm
		SIZE	A	B	C	H
	1"	184.2	117.0	58.3	128.4	
	1 1/2"	198.4	142.7	61.0	164.4	
	2"	223.8	144.2	72.4	178.3	
	2 1/2"	260.4	150.6	86.2	223.4	
	3"	290.5	180.7	90.6	241.4	

PLV-2T-WR 2通焊式考克閥 (橡膠軸) PLV-2T-WS 2通焊式考克閥 (不銹鋼軸)	2 Way Plug Valve Weld Ends				Rubber Plug SS Plug	mm
		SIZE	A	B	C	H
						" for Welding on Threaded Male Ends "
	1"	90.5	117.0	58.3	128.4	
	1 1/2"	122.2	142.7	61.0	164.4	
	2"	147.6	144.2	72.4	178.3	
	2 1/2"	184.2	150.6	86.2	223.4	
	3"	214.4	180.7	90.6	241.4	

PLV-3T-WR 3通焊式考克閥 (橡膠軸) PLV-3T-WS 3通焊式考克閥 (不銹鋼軸)	3 Way Plug Valve Weld Ends				Rubber Plug SS Plug	mm
		SIZE	A	B	C	H
						" for Welding on Threaded Male Ends "
	1"	90.5	117.0	58.3	128.4	
	1 1/2"	122.2	142.7	61.0	164.4	
	2"	147.6	144.2	72.4	178.3	
	2 1/2"	184.2	150.6	86.2	223.4	
	3"	214.4	180.7	90.6	241.4	